

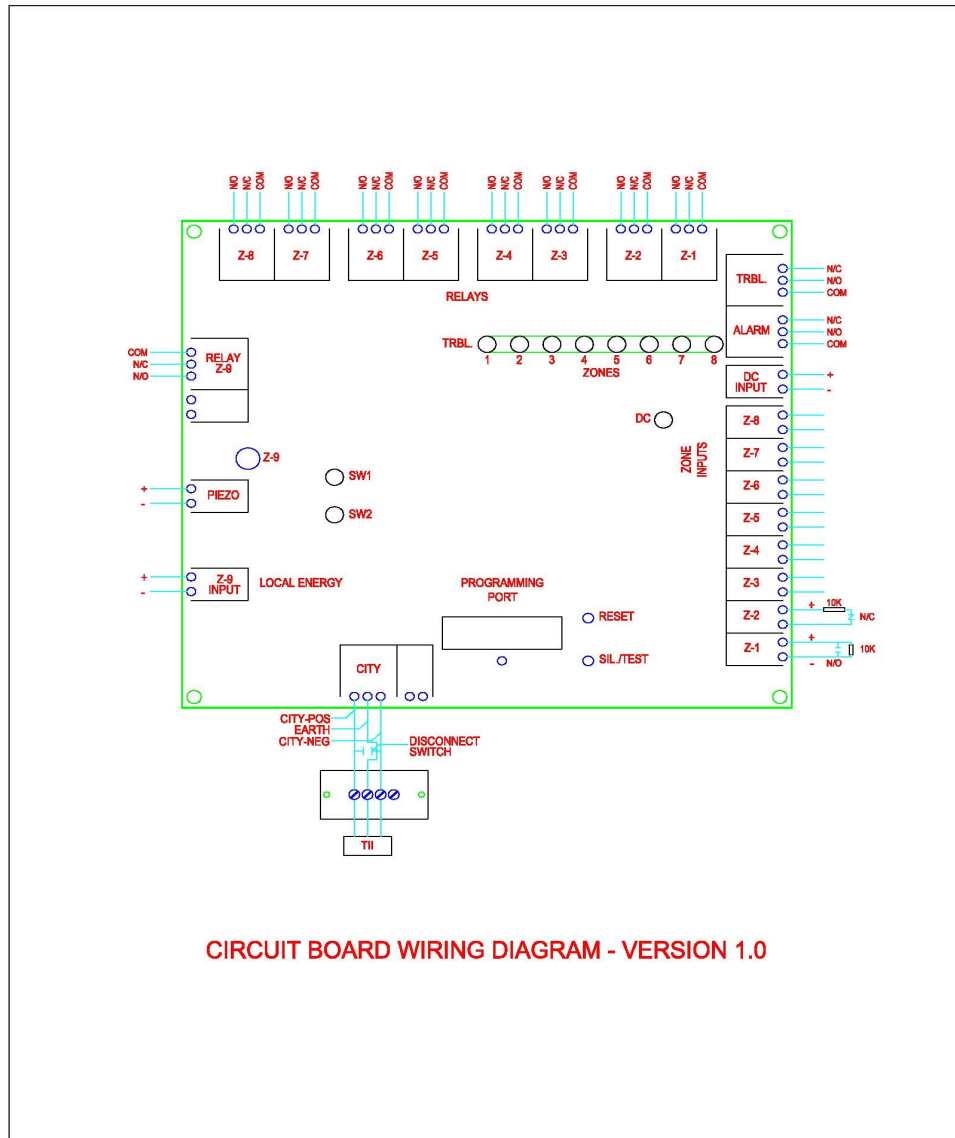

Kingfisher Company, inc.

# Circuit Board Wiring Diagram Version 1.0



CIRCUIT BOARD WIRING DIAGRAM - VERSION 1.0

Kingfisher Company, inc., products must be used within their published specifications and must be PROPERLY specified, applied, installed, operated, maintained and operationally tested in accordance with their installation instructions at the time of installation and at least twice a year or more often and in accordance with local, state and federal codes, regulations and laws. Specification, application, installation, operation, maintenance and testing must be performed by qualified personnel for proper operation in accordance with all of the latest National Fire Protection Association (NFPA), Underwriters' Laboratories (UL), National Electrical Code (NEC), Occupational Safety and Health Administration (OSHA), local, state, county, province, district, federal and other applicable building and fire standards, guidelines, regulations, laws and codes including, but not limited to, all appendices and amendments and the requirements of the local authority having jurisdiction (AHJ).

NOTE: Due to continuous development of our products, specifications and offerings are subject to change without notice in accordance with Kingfisher Company, inc., standard terms and conditions

**Kingfisher Company, inc.** 81 Old Ferry Road - Lowell, MA 01854  
Phone: 978-596-0214 Fax: 978-596-0217 [www.kfci.com](http://www.kfci.com)