



Kingfisher Company, inc.

81 Old Ferry Road, Lowell, Ma. 01815

Phone: (978) 596-2014 Fax: (978) 596-2017

Website: www.kfci.com Email: info@kfci.com



The City Master Box Electronic Alarm Transmitter



Installation & Operation Manual



CITY MASTER BOX
ELECTRONIC TELEGRAPHIC ALARM TRANSMITTER

1. Product Overview

The City Master Box (CMB) is an NFPA 72 compliant electronic coded transmitter for use on telegraphic fire alarm reporting systems. The CMB has been engineered and built with rigged

components to provide many years of trouble-free service.

The CMB is comprised of a rugged solid-state microprocessor based circuit board mounted to a durable mounting plate with a city loop terminal block, disconnect switch and a TII transient voltage suppressor. The mounting plate allows for easy installation or replacement in any type of existing or customer supplied enclosure.

Two NEMA 1 enclosures are available for indoor installations. The Standard enclosure houses the CMB only. The larger Power Supply enclosure houses the CMB, power supply/battery charger and batteries. The power supply requires two 12V Sealed Lead Acid or Gel Cell type batteries. Batteries are customer supplied.

The CMB operates on 24VDC, filtered and regulated input power. The power source is typically supplied from a Fire Alarm Control Panel (FACP) but it may be powered by any listed or approved power supply source having supervised battery charging and standby power.

Eight programmable input zones and eight respective zone relays are provided. Each input zone can be programmed as a normally open or normally closed initiating circuit actuated by any dry contact relay or device. A local energy trip input is also provided. Normally open circuits are supervised using a 10K end of line resistor installed across the circuit at the last contact device on the circuit. Normally closed circuits are supervised using a 10K end of line resistor installed in series with the last contact device on the circuit. All circuits are supervised for opens, shorts and ground fault conditions.

Plug in connector terminals are provided for all field wiring. The connectors allow for easy trouble shooting or board removal and replacement.

A piezo sounder is provided that will actuate on either trouble or alarm. The sounder is silenceable, however, any subsequent alarm or trouble will re-actuate the sounder. Any alarm condition will actuate the respective zone relay and the general alarm relay. The failsafe trouble relay is normally energized and any trouble condition will de-energize the relay causing to change state.

All functions of the CMB are field programmable using a desktop or laptop computer or an iOS or Android handheld device with Bluetooth interface. Some on-board functions and programming can also be performed using the onboard rotary switches.

2. Hardware Specifications

	MIN	TYP	MAX	UNITS
External Power Supply				
Voltage	20	24-30	30	VDC
Current	47	196	500	mA
Input Characteristics for 8 supervised zones				
Supervisory (internally generated)				
Voltage	0		30	VDC
Current	0		3	mA
External device (typically dry contacts) including external wiring				
Closed	0		1K	ohms
Open	1M			ohms
EOL		10K		ohms
Input Characteristics for 1 Local energy zone				
External device (typically FACP)				
Voltage	0		40	VDC
Alarm	18	20	60	mA
Supervisory	0	4	8	mA
Output Characteristics				
Relay contacts				
			0.05	ohms
30VDC			2	A
120VAC			1	A
Isolation	1500			VDC
Operating Temperature				
	-40		+70	C
Operating Humidity				
Non-condensing			90	%

I/O Configuration

Inputs

1	DC power source (+24V)
1	External PC (9 pin RS-232 receptacle)
2	10 position rotary switches (test & manual program)
1	Reset pushbutton
1	Test pushbutton
8	Supervised dry contact zones
1	Local energy trip monitor

Outputs

1	Power Source annunciator LED (green)
1	Audible annunciator
8	Alarm annunciator LEDs (red)
8	Alarm annunciator DPDT relays
1	Common alarm annunciator relay
1	Common trouble annunciator LED (yellow)
1	Common trouble annunciator relay
1	Local energy trip annunciator LED (red)
1	Local energy trip annunciator relay
1	Telegraphic signaling loop
1	Emergency Ground Return circuit

3. Transmitter Installation Instructions

EACH TRANSMITTER IS SHIPPED COMPLETELY ASSEMBLED AND INSTALLED IN THE ENCLOSURE SPECIFIED WHEN ORDERED. THE TRANSMITTER IS THE SAME UNIT REGARDLESS OF THE TYPE OF ENCLOSURE.

Each transmitter is shipped completely assembled and installed in the enclosure specified when ordered. The Transmitter is the same unit regardless of the enclosure type.

ALL WIRING SHALL BE IN ACCORDANCE WITH ALL FEDERAL, STATE AND LOCAL CODE REQUIREMENTS INCLUDING BUT NOT LIMITED TO THE REQUIREMENTS OF THE NATIONAL ELECTRICAL CODE NFPA STANDARD 70 AND THE NATIONAL FIRE ALARM CODE NFPA 72.

1. Connect regulated / filtered 24VDC power from an FM or NRTL approved power supply to the DC input terminals. Observe polarity as shown on the wiring diagram.
2. If using internal power supply version, connect AC power input to 120VAC nominal AC line source. It is recommended that the CMB be wired with its own breaker. Connect the standby batteries to the power supply BAT+ and BAT- terminals.
3. Connect the city loop circuit and the surge suppressor to the terminal block as shown on the wiring diagram. Ground the circuit in accordance with the requirements of the AHJ.
4. For local energy trip, connect the municipal trip circuit from the FACP to the Local Energy Input Z9. The municipal trip circuit must comply with the requirements as set forth in NFPA-72. Observe polarity as shown on the wiring diagram.
5. For activation by dry contact zones, connect the NO or NC dry contact devices to the respective input zones. Install a 10K resistor across the device contacts for NO circuits. Install a 10K resistor in series with the circuit for NC circuits. Program each circuit for NO or NC activation as required for the application.
6. Install a 10K resistor across the zone terminals for proper supervision of all unused zones.
7. Program the zone and system functions per application and AHJ requirements.
8. Test the transmitter by shorting a NO input zone or opening a NC input zone. The zone relay and general alarm relay will actuate. Verify that the appropriate alarm LED illuminates, and the Piezo sounder sounds. The sounder will operate on any alarm or trouble condition, and can be silenced via the SIL/TEST button. The sounder will resound on any subsequent alarm or trouble condition.
9. Loss of the city circuit or operation of the disconnect switch can be programmed to either force a trouble condition, or not.
10. Each input zone and the local energy trip zone is automatically assigned to a corresponding SPDT dry contact annunciation relay. Test corresponding relays for activation, if used.

4. Terminal Designations

City Masterbox Main board:

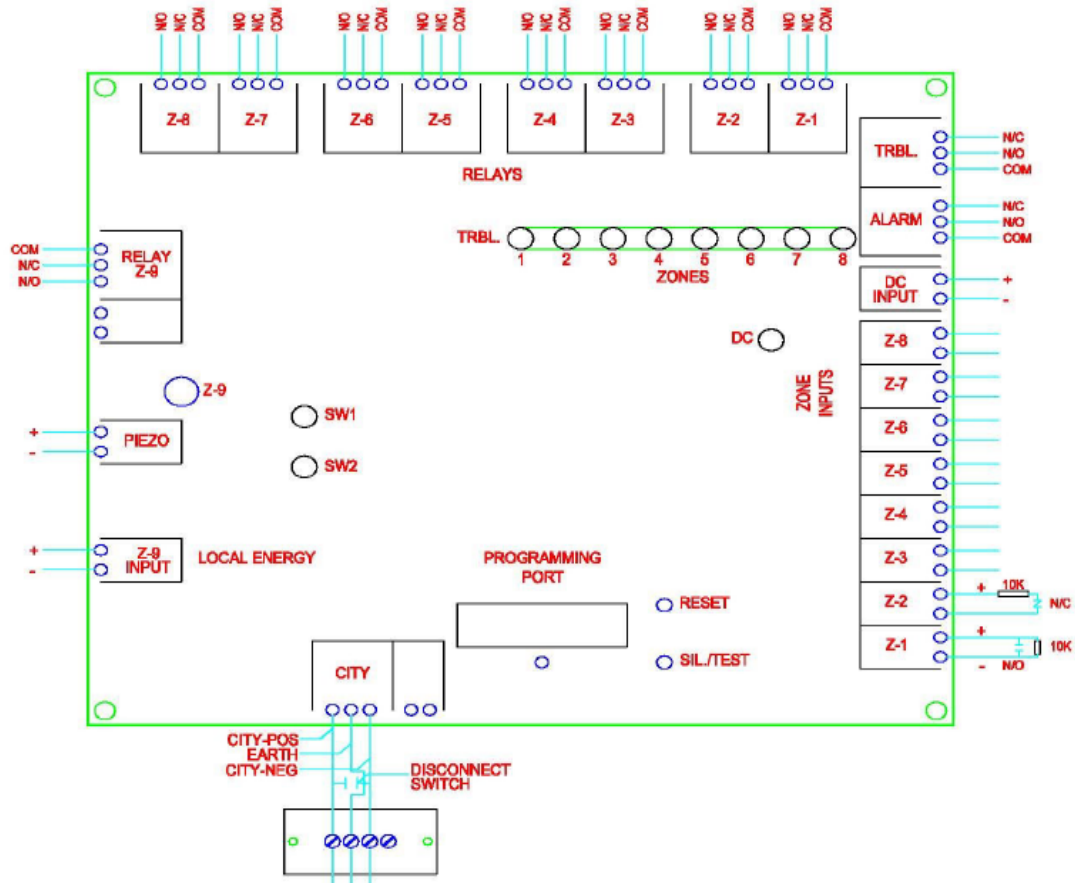

Connector	Terminal	Function
Z-9	+	Local Energy + input from FACP
Z-9	-	Local Energy – input from FACP
Piezo	+	+ connection to local sounder
Piezo	-	- connection to local sounder
Relay Z-9	COM	Common terminal for local energy Zone 9 annunciation relay
Relay Z-9	N/C	Normally Closed contact terminal for local energy Zone 9 annunciation relay
Relay Z-9	N/O	Normally Open contact terminal for local energy Zone 9 annunciation relay
Relay Z-8	COM	Common terminal for input Zone 8 annunciation relay
Relay Z-8	N/C	Normally Closed contact terminal for input Zone 8 annunciation relay
Relay Z-8	N/O	Normally Open contact terminal for input Zone 8 annunciation relay
Relay Z-7	COM	Common terminal for input Zone 7 annunciation relay
Relay Z-7	N/C	Normally Closed contact terminal for input Zone 7 annunciation relay
Relay Z-7	N/O	Normally Open contact terminal for input Zone 7 annunciation relay
Relay Z-6	COM	Common terminal for input Zone 6 annunciation relay
Relay Z-6	N/C	Normally Closed contact terminal for input Zone 6 annunciation relay
Relay Z-6	N/O	Normally Open contact terminal for input Zone 6 annunciation relay
Relay Z-5	COM	Common terminal for input Zone 6 annunciation relay

Relay Z-5	N/C	Normally Closed contact terminal for input Zone 5 annunciation relay
Relay Z-5	N/O	Normally Open contact terminal for input Zone 5 annunciation relay
Relay Z-4	COM	Common terminal for input Zone 5 annunciation relay
Relay Z-4	N/C	Normally Closed contact terminal for input Zone 4 annunciation relay
Relay Z-4	N/O	Normally Open contact terminal for input Zone 4 annunciation relay
Relay Z-3	COM	Common terminal for input Zone 3 annunciation relay
Relay Z-3	N/C	Normally Closed contact terminal for input Zone 3 annunciation relay
Relay Z-3	N/O	Normally Open contact terminal for input Zone 3 annunciation relay
Relay Z-2	COM	Common terminal for input Zone 2 annunciation relay
Relay Z-2	N/C	Normally Closed contact terminal for input Zone 2 annunciation relay
Relay Z-2	N/O	Normally Open contact terminal for input Zone 2 annunciation relay
Relay Z-1	COM	Common terminal for input Zone 1 annunciation relay
Relay Z-1	N/C	Normally Closed contact terminal for input Zone 1 annunciation relay
Relay Z-1	N/O	Normally Open contact terminal for input Zone 1 annunciation relay
TRBL	COM	Common terminal for general trouble annunciation relay
TRBL	N/C	Normally Closed contact terminal for general trouble annunciation relay
TRBL	N/O	Normally Open contact terminal for general trouble annunciation relay
ALARM	COM	Common terminal for general alarm annunciation relay
ALARM	N/C	Normally Closed contact terminal for general alarm annunciation relay
ALARM	N/O	Normally Open contact terminal for general alarm annunciation relay
DC INPUT	+	+24VDC power input from FM Approved FACP or power source
DC INPUT	-	24VDC power return from FM Approved FACP or power source
Input Z-8	+	Input Zone 8 + terminal. Connects to dry contact, supervised with 10K EOLR
Input Z-8	-	Input Zone 8 - terminal. Connects to dry contact, supervised with 10K EOLR
Input Z-7	+	Input Zone 7 + terminal. Connects to dry contact, supervised with 10K EOLR
Input Z-7	-	Input Zone 7 - terminal. Connects to dry contact, supervised with 10K EOLR
Input Z-6	+	Input Zone 6 + terminal. Connects to dry contact, supervised with 10K EOLR
Input Z-6	-	Input Zone 6 - terminal. Connects to dry contact, supervised with 10K EOLR
Input Z-5	+	Input Zone 5 + terminal. Connects to dry contact, supervised with 10K EOLR
Input Z-5	-	Input Zone 5 - terminal. Connects to dry contact, supervised with 10K EOLR
Input Z-4	+	Input Zone 4 + terminal. Connects to dry contact, supervised with 10K EOLR
Input Z-4	-	Input Zone 4 - terminal. Connects to dry contact, supervised with 10K EOLR
Input Z-3	+	Input Zone 3 + terminal. Connects to dry contact, supervised with 10K EOLR
Input Z-3	-	Input Zone 3 - terminal. Connects to dry contact, supervised with 10K EOLR
Input Z-2	+	Input Zone 2 + terminal. Connects to dry contact, supervised with 10K EOLR
Input Z-2	-	Input Zone 2 - terminal. Connects to dry contact, supervised with 10K EOLR
Input Z-1	+	Input Zone 1 + terminal. Connects to dry contact, supervised with 10K EOLR
Input Z-1	-	Input Zone 1 - terminal. Connects to dry contact, supervised with 10K EOLR
CITY	POS	Positive leg of municipal signaling loop
CITY	EARTH	Earth ground leg of municipal signaling loop
CITY	NEG	Negative / return leg of municipal signaling loop
LED Indicators		
LED1	Trouble	Yellow trouble LED, illuminates when any trouble condition is present
LED2	Z1 Alarm	Red Zone 1 Alarm LED, illuminates when Input Zone 1 is in alarm
LED3	Z2 Alarm	Red Zone 2 Alarm LED, illuminates when Input Zone 2 is in alarm
LED4	Z3 Alarm	Red Zone 3 Alarm LED, illuminates when Input Zone 3 is in alarm
LED5	Z4 Alarm	Red Zone 1 Alarm LED, illuminates when Input Zone 1 is in alarm
LED6	Z5 Alarm	Red Zone 2 Alarm LED, illuminates when Input Zone 2 is in alarm
LED7	Z6 Alarm	Red Zone 3 Alarm LED, illuminates when Input Zone 3 is in alarm
LED8	Z7 Alarm	Red Zone 4 Alarm LED, illuminates when Input Zone 4 is in alarm
LED9	Z8 Alarm	Red Zone 4 Alarm LED, illuminates when Input Zone 4 is in alarm

5. Operation

SIL/TEST Pushbutton

When the SIL/TEST pushbutton is pressed, the audible device will be silenced, and the following actions will be performed, depending on the positions of SW1 & SW2.

SW1 selects an option, SW2 determines the zone to which the option applies.

SW1 = 0 = SOUND AUDIBLE DEVICE

SW1 = 1 = RELOAD from EEPROM

SW1 = 2 = LOAD DEFAULTS

SW1 = 3 = LOAD DEFAULTS & WRITE THEM TO EEPROM SW1 = 4 =
SUSPEND ZONE (ZONE = SW2)

SW1 = 5 = ACTIVATE ZONE (ZONE = SW2)

SW1 = 6 = SEND ALARM CODE ON LOOP (ZONE = SW2) SW1 = 7 =

SEND TROUBLE CODE ON LOOP (ZONE = SW2) SW1 = 8 =
OPERATE ANNUNCIATORS (ZONE = SW2)

SW1 = 9 = Not used

If SW1 = 0-3, then SW2 is not used.

SW2 = 0 through 9 = Not used

If SW1 = 4-7, then SW2 selects an input zone.

SW2 = 0 = Not used

SW2 = 1 = Zone 1

SW2 = 2 = Zone 2

SW2 = 3 = Zone 3

SW2 = 4 = Zone 4

SW2 = 5 = Zone 5

SW2 = 6 = Zone 6

SW2 = 7 = Zone 7

SW2 = 8 = Zone 8

SW2 = 9 = Local Energy zone

If SW1 = 8, then SW2 selects the annunciator outputs.

SW2 = 0 = common TRBL (LED & relay)

SW2 = 1 = Zone 1 (LED & relay)

SW2 = 2 = Zone 2 (LED & relay)

SW2 = 3 = Zone 3 (LED & relay)

SW2 = 4 = Zone 4 (LED & relay)

SW2 = 5 = Zone 5 (LED & relay)

SW2 = 6 = Zone 6 (LED & relay)

SW2 = 7 = Zone 7 (LED & relay)

SW2 = 8 = Zone 8 (LED & relay)

SW2 = 9 = Local Energy (LED & relay)

Sound Audible Device

The audible device may be tested by setting SW1 = 0 and pressing the SIL/TEST pushbutton. The audible device will sound for as long as the SIL/TEST pushbutton is pressed.

Configuration and Defaults

The configuration information that is downloaded from a programming utility is stored in the EEPROM memory. The factory default configuration is embedded in the software program.

Upon reset (power-up or RESET pushbutton), the configuration stored in the EEPROM memory is checked for corruption. If no corruption is detected then the uP memory is loaded from the EEPROM memory. If the EEPROM memory is found to be corrupted then the uP memory is loaded with the factory default configuration.

The board can be manually forced to reload its configuration memory from EEPROM by setting SW1 = 1 and pressing the SIL/TEST pushbutton. Since the microprocessor is not reset by this operation, the "run time" data stored in the uP memory is not lost. This may be useful for troubleshooting and/or production testing.

The unit can be manually forced to reload the factory default values into its configuration memory by setting SW1 = 2 and pressing the SIL/TEST pushbutton. Note that loading the factory default values into microprocessor memory does not alter the contents of the EEPROM memory, and the Microprocessor memory may be reloaded from EEPROM memory again at any time.

Setting SW1 = 3 and pressing the SIL/TEST pushbutton will reload the factory default values (embedded in software) into the uP memory, and will store them in the EEPROM memory. The original EEPROM memory contents will be over-written.

Suspend Zone(s)

Any input zone may be manually suspended by setting SW1 = 4 and pressing the SIL/TEST pushbutton. The input zone to be suspended is selected by SW2.

If SW2 = 0 then all input zones will be activated.

If SW2 = 1 through 8, then the selected zone will be suspended.

1. The red LED for the selected zone will extinguish.
2. The relay for the selected zone will be de-energized.
3. The selected zone will not operate the common ALARM LED.
4. The selected zone will not operate the common ALARM relay.
5. The selected zone will operate the common TRBL LED.
6. The selected zone will operate the common TRBL relay.
7. A Trouble Code may be transmitted (configuration dependent).

If SW2 = 9, then the Local Energy zone will be suspended.

1. The red Local Energy LED will extinguish.
2. The Local Energy relay will be de-energized.
3. The Local Energy zone will not operate the common ALARM LED.
4. The Local Energy zone will not operate the common ALARM relay.
5. The Local Energy zone will operate the common TRBL LED.
6. The Local Energy zone will operate the common TRBL relay.
7. A Trouble Code may be transmitted (configuration dependent).

A zone can be suspended only by means of the SIL/TEST pushbutton. It cannot be suspended by a download from a programming utility. A suspended input zone will not respond to any status changes (alarm, trouble, restore).

A suspended input zone will remain suspended until it is manually activated.
If the unit is reset (power-up or RESET pushbutton), then all input zones are activated, i.e. all "zone suspends" are cleared.

Zone Test – Manual Zone Activation

Any input zone may be manually activated by setting SW1 = 5 and pressing the SIL/TEST pushbutton. The input zone to be activated is selected by SW2.

If SW2 = 0 then all input zones will be activated.

If SW2 = 1 through 8, then the selected zone will be activated. If SW2 = 9, then the Local Energy zone will be activated.

Alarm Simulation

An alarm condition may be simulated for any input zone by setting SW1 = 6 and pressing the SIL/TEST pushbutton. The input zone to be simulated is selected by SW2.

If SW2 = 0, then no input zone will be simulated. No CODE will be transmitted. The following conditions will be established for as long as the SIL/TEST pushbutton is pressed.

1. The red common ALARM LED will illuminate.
2. The common ALARM relay will operate.

If SW2 = 1 through 8, then an alarm condition will be simulated for the selected input zone. The alarm CODE assigned to the selected input zone will be transmitted on the municipal loop and/or Emergency Ground Return circuit, using the "transmit" configuration parameters assigned to the selected input zone. The following conditions will be established for as long as the SIL/TEST pushbutton is pressed.

1. The red LED for the selected input zone will illuminate.
2. The annunciator relay for the selected input zone will operate.
3. The red common ALARM LED will illuminate.
4. The common ALARM relay will operate.

If SW2=9, then an alarm condition will be simulated for the Local Energy zone.

The alarm CODE assigned to the Local Energy zone will be transmitted on the municipal loop and/or Emergency Ground Return circuit, using the "transmit" configuration parameters assigned to the Local Energy zone. The following conditions will be established for as long as the SIL/TEST pushbutton is pressed.

1. The red Local Energy LED will illuminate.
2. The Local Energy relay will operate.
3. The red common ALARM LED will illuminate.
4. The common ALARM relay will operate.

Trouble Simulation

A trouble condition may be simulated for any input zone by setting SW1 = 7 and pressing the SIL/TEST

pushbutton. The input zone to be simulated is selected by SW2.

If SW2 = 0, then no input zone will be simulated. No CODE will be transmitted. The following conditions will be established for as long as the SIL/TEST pushbutton is pressed.

1. The yellow common TRBL LED will illuminate.
2. The common TRBL relay will operate.

If SW2 = 1 through 8, then a trouble condition will be simulated for the selected input zone. The trouble CODE assigned to the selected input zone will be transmitted on the municipal loop and/or Emergency Ground Return circuit, using the "transmit" configuration parameters assigned to the selected input zone. The following conditions will be established for as long as the SIL/TEST pushbutton is pressed.

1. The yellow common TRBL LED will illuminate.
2. The common TRBL relay will operate.

If SW2=9, then a trouble condition will be simulated for the Local Energy zone. The trouble CODE assigned to the Local Energy zone will be transmitted on the municipal loop and/or Emergency Ground Return circuit, using the "transmit" configuration parameters assigned to the Local Energy zone. The following conditions will be established for as long as the SIL/TEST pushbutton is pressed.

1. The yellow common TRBL LED will illuminate.
2. The common TRBL relay will operate.

Annunciator Tests

The annunciator outputs may be manually operated by setting SW1 =8 and pressing the SIL/TEST pushbutton. The annunciator output to be operated is selected by SW2.

1. If SW2 = 0 then the following conditions will be established for as long as the SIL/TEST pushbutton is pressed.
2. The yellow common TRBL yellow LED will illuminate.
3. The common TRBL relay will operate.

If SW2 = 1 through 8, then the following conditions will be established for as long as the SIL/TEST pushbutton is pressed.

1. The red LED for the selected zone will illuminate.
2. The annunciator relay for the selected zone will operate.
3. The red common ALARM LED will illuminate.
4. The common ALARM relay will operate.

If SW2 = 9, then the following conditions will be established for as long as the SIL/TEST pushbutton is pressed.

1. The red Local Energy LED will illuminate.
2. The Local Energy relay will operate.
3. The red common ALARM LED will illuminate.
4. The common ALARM relay will operate.

6. Input Zones

The input zones will detect an alarm condition when the input voltage exceeds 75% of the unit's power source voltage. For example:

	<u>Alarm Trip Voltage</u>	<u>Trouble Trip Voltage</u>
Unit power source = 24VDC	6.0 VDC	18.0VDC
Unit power source = 30VDC	7.5 VDC	22.5VDC

Events on the input zones, the Local Energy zone, and the SIL/TEST must be active for > 1 second in order to trip the system.

Alarm

If an input zone is put into an alarm condition, the alarm CODE assigned to the input zone will be transmitted on the municipal loop and/or Emergency Ground Return circuit, using the (transmit) configuration parameters assigned to the input zone. The following conditions will be established for as long as the input zone is in an alarm condition:

1. The red LED for the selected input zone will illuminate.
2. The annunciator relay for the selected input zone will operate.
3. The red common ALARM LED will illuminate.
4. The common ALARM relay will operate.

Trouble

If an input zone is put into a trouble condition, the trouble CODE assigned to the input zone will be transmitted on the municipal loop and/or Emergency Ground Return circuit, using the (transmit) configuration parameters assigned to the input zone. The following conditions will be established for as long as the input zone is in a trouble condition:

1. The yellow common TRBL LED will illuminate.
2. The common TRBL relay will operate.

Suspended

If an input zone is suspended, the trouble CODE assigned to the input zone will be transmitted on the municipal loop and/or Emergency Ground Return circuit, using the (transmit) configuration parameters assigned to the input zone. The following conditions will be established for as long as the input zone is suspended:

1. The red LED for the selected zone will extinguish.
2. The relay for the selected zone will be de-energized.
3. The selected zone will not operate the common ALARM LED.
4. The selected zone will not operate the common ALARM relay.
5. The selected zone will operate the common TRBL LED.
6. The selected zone will operate the common TRBL relay.

A zone can be suspended only by means of the SIL/TEST pushbutton. It cannot be suspended by a download from a programming utility. See **Disabled**.

1. A suspended input zone will not respond to any status changes (alarm, trouble, restore).
2. A suspended input zone will remain suspended until it is manually activated.
3. If the unit is reset (power-up or RESET pushbutton), then all input zones are activated, i.e. all "zone suspends" are cleared.

Disabled

If an input zone is disabled, it will behave as if the input is in a normal condition, i.e., no CODEs are transmitted, no LEDs are operated, and no relays are operated.

Input zones can only be disabled (or activated) by a setting in the configuration (downloaded from a PC). Zones cannot be disabled (or activated) without downloading. This setting is intended for zones that will not be used in the application.

7. Local Energy Input Zone

The Local Energy input zone will detect an alarm condition when the Local Energy input voltage exceeds 80% of the unit's power source voltage. For example:

	<u>Trip Voltage</u>	<u>Trip Current</u>
Unit power source=24VDC	19.8 VDC	15mA
Unit power source=30VDC	24.7 VDC	24mA

Alarm

If the Local Energy input zone is put into an alarm condition, the alarm CODE assigned to the Local Energy input zone will be transmitted on the municipal loop and/or Emergency Ground Return circuit, using the (transmit) configuration parameters assigned to the Local Energy input zone. The following conditions will be established for as long as the Local Energy input zone is in an alarm condition:

1. The red Local Energy LED will illuminate.
2. The Local Energy relay will operate.
3. The red common ALARM LED will illuminate.
4. The common ALARM relay will operate.

Trouble

The Local Energy input zone does not have an input trouble condition, however, a trouble CODE may be transmitted if the Local Energy input zone is suspended.

Suspended

If the Local Energy input zone is suspended, the trouble CODE assigned to the Local Energy input zone will be transmitted on the municipal loop and/or Emergency Ground Return circuit, using the (transmit) configuration parameters assigned to the Local Energy input zone. The following conditions will be

established for as long as the Local Energy input zone is suspended:

1. The red Local Energy LED will extinguish.
2. The Local Energy relay will be de-energized.
3. The Local Energy zone will not operate the common ALARM LED.
4. The Local Energy zone will not operate the common ALARM relay.
5. The Local Energy zone will operate the common TRBL LED.
6. The Local Energy zone will operate the common TRBL relay.

If the Local Energy input zone is suspended, it will not respond to any status changes (alarm, trouble, restore).

If the Local Energy input zone is suspended, it will remain suspended until it is manually activated, or the unit is reset. If the unit is reset (power-up or RESET pushbutton), then all input zones are enabled, i.e. the Local Energy "zone suspend" is cleared.

Disabled

If the Local Energy zone is disabled, it will behave as if the Local Energy input zone is in a normal condition, i.e., no CODEs are transmitted, no LEDs are operated, and no relays are operated.

The Local Energy zone can only be disabled (or activated) by a setting in the configuration (downloaded from a PC). It cannot be disabled (or activated) without downloading. This setting is intended for applications that will not use the Local Energy zone.

8. Audible Device

The audible device will sound when an input zone (including the Local Energy input zone) enters an alarm, supervisory, or trouble condition. It will continue to sound until the input zone restores, or the SIL/TEST pushbutton is pressed.

9. Common Trouble Relay

This relay is used in an inverse logic manner. If no trouble conditions exist, it is energized. If any trouble condition exists, it is de-energized. The NO contacts are used as if they were the NC contacts, and the NC contacts are used as if they were the NO contacts. This allows a power failure to appear as a trouble (relay de-energizes)

10. LED Indicators

LED1	Trouble	Yellow trouble LED, illuminates when any trouble condition is present
LED2	Z1 Alarm	Red Zone 1 Alarm LED, illuminates when Input Zone 1 is in alarm
LED3	Z2 Alarm	Red Zone 2 Alarm LED, illuminates when Input Zone 2 is in alarm
LED4	Z3 Alarm	Red Zone 3 Alarm LED, illuminates when Input Zone 3 is in alarm
LED5	Z4 Alarm	Red Zone 1 Alarm LED, illuminates when Input Zone 1 is in alarm
LED6	Z5 Alarm	Red Zone 2 Alarm LED, illuminates when Input Zone 2 is in alarm
LED7	Z6 Alarm	Red Zone 3 Alarm LED, illuminates when Input Zone 3 is in alarm
LED8	Z7 Alarm	Red Zone 4 Alarm LED, illuminates when Input Zone 4 is in alarm
LED9	Z8 Alarm	Red Zone 4 Alarm LED, illuminates when Input Zone 4 is in alarm

11. Programming Parameters

The following parameters are user programmable via a variety of means, including Windows laptop and Bluetooth Android or iOS handheld device platforms.

Zone Input (trip) Circuits Configuration

The following items are programmable for each input trip circuit.

ALARM CODE. This is the code number that will be transmitted when the input enters an alarm state, i.e. the external dry contact goes open on a normally closed (N/C) input, or closed on a normally open (NO) input.

- This value may be up to 6 digits long, and may range from 0 to 999999. Leading zeros are ignored.
- Embedded zeros will cause a “ten” digit to be transmitted if the “embedded zeros” option is enabled.
- Embedded zeros will be interpreted as an erroneous code number, and no transmission will occur if the “embedded zeros” option is disabled
- A code number of all zeros will be interpreted as a “transmit disable”, and no transmission will occur, however the zone alarm LED, the zone relay, and the common alarm relay will still respond to the input circuit.
- A code number of all ones is permitted, but not recommended, since a receiving device may misinterpret the transmission as a single digit, i.e. 111 may appear as 3.

ALARM ROUNDS. This is the number of times that the alarm code number will be transmitted when the input circuit enters an alarm state.

Values may range from 0 to 255

TROUBLE CODE. This is the code that will be transmitted when the input circuit enters a trouble state, i.e. the external dry contact circuit goes open (broken).

Trouble codes have the same conditions as alarm codes (see above).

TROUBLE ROUNDS. This is the number of times that the trouble code number will be transmitted when the input circuit goes open (broken).

Trouble rounds have the same conditions as alarm rounds (see above).

INPUT POLARITY (N/O N/C). This option allows you to specify whether the external dry contact is normally open (NO) or normally closed (NC).

On a normally closed (NC) external dry contact, a missing or disconnected “end-of-line” resistor would not be detected until the contact opened (activated for an alarm condition), at which time both an “alarm” code and a “trouble” code would be transmitted.

Note that the Local Energy input is typically NO. It may be set to NC for other purposes.

ALLOW ALL ONES IN CODES. If this option is enabled, then “all ones” codes, i.e. 1, 11, 111, 1111, 11111, 111111, 1111111, and 11111111 will be allowed. A code number of all ones is permitted, but not recommended, since a receiving device may misinterpret the transmission as a single digit, i.e. 4

rounds of code number 111 may appear as 1 round of code number 3333.

If this option is disabled, then a code number of all ones will be ignored, and no transmission will occur.

ALLOW EMBEDDED ZEROS IN CODES. Embedded zeros are zeros that come after the first non-zero digit, and before the decimal point.

If this option is enabled, then embedded zeros will cause a “ten” digit to be transmitted. Leading zeros are always ignored. Example: Code number 00001040 would be transmitted as 1 10 4 10.

If this option is disabled, then embedded zeros will be interpreted as an erroneous code number, and no transmission will occur.

ALLOW E.G.R. MODE FOR TROUBLE. This option allows you to specify whether or not a trouble transmission will be allowed in the Emergency Ground Return (E.G.R) mode for a trouble state on the input.

If the municipal loop is broken, i.e. it has been open for longer the “dead-time” setting (see **Transmitter Configuration**), and this option is enabled, then the trouble transmission will occur in E.G.R. mode.

If the municipal loop is broken, i.e. it has been open for longer the “dead-time” setting (see **Transmitter Configuration**), and this option is disabled, then the trouble transmission will be discarded and no transmission will occur.

ALLOW BULLDOG MODE FOR ALARM. The option allows you to specify whether or not “bulldog” mode will be allowed for an alarm state on the input.

A bulldog operation can occur only if both the municipal loop and the Emergency Ground Return circuit are unavailable.

If the municipal loop is broken, i.e. it has been open for longer the “dead-time” setting (see **Transmitter Configuration**), then the alarm transmission will be attempted in E.G.R. mode. If interference is detected in E.G.R. mode, then the transmitter will wait for the amount of time specified in “dead-time” (see **Transmitter Configuration**), and will again try to transmit, first on the municipal loop, then on the E.G.R. circuit. This sequence of attempts will continue until either the “maximum number of allowable tries” have been attempted, or the “bulldog-time” has expired.

If this option is enabled, then a “bulldog” operation will be performed, i.e. the code number will be transmitted first on the municipal loop, and then on the E.G.R. circuit, regardless of interference or circuit condition.

Note that if either the municipal loop or the E.G.R. circuit is configured as non- PNIS, then transmission will, of course, occur prior to any bulldog operation.

If this option is disabled, then the pending transmission will be discarded after the “maximum number of tries” have been attempted, and no transmission will occur.

ALLOW BULLDOG MODE FOR TROUBLE. The option allows you to specify whether or not “bulldog” mode will be allowed for a trouble state on the input.

A bulldog operation can occur only if both the municipal loop and the Emergency Ground Return circuit are unavailable.

If the municipal loop is broken, i.e. it has been open for longer the “dead-time” setting (see **Transmitter Configuration**), then the trouble transmission will be attempted in E.G.R. mode ONLY if the “allow E.G.R. mode for trouble” option is enabled. If interference is detected in E.G.R. mode, or if the “allow E.G.R. mode for trouble” option is disabled, then the transmitter will wait for the amount of time specified in “dead-

time” (see **Transmitter Configuration**), and will again try to transmit, first on the municipal loop, then on the E.G.R. circuit. This sequence of attempts will continue until either the “maximum number of allowable tries” have been attempted, or the “bulldog-time” has expired.

If this option is enabled, then a “bulldog” operation will be performed, i.e. the code number will be transmitted first on the municipal loop, and then on the E.G.R. circuit (if the “allow E.G.R. mode for trouble” option is enabled) regardless of interference or circuit condition.

Note that if the municipal loop is configured for non-PNIS or if the E.G.R. circuit is configured as non-PNIS (and the “allow E.G.R. mode for trouble” option is enabled), then transmission will, of course, occur prior to any bulldog operation.

If this option is disabled, then the pending transmission will be discarded after the “maximum number of tries” have been attempted, and no transmission will occur.

Transmitter Global Parameters Configuration

The following items pertain to all input zone circuits.

LOOP IS POSITIVE NON-INTERFERING SUCCESSIVE. This option allows you to specify whether or not the transmitter will monitor the municipal loop for other transmitters.

If this option is enabled, then all transmissions on the municipal loop will be monitored for interference. If another transmitter is detected on the municipal loop, then all pending transmissions will be postponed until the municipal loop is available.

If a transmission is in progress when another transmitter is detected, then the municipal loop will be relinquished until the municipal loop is available, at which time all programmed rounds of the code number will be transmitted.

If this option is disabled, then the transmitter will not relinquish the municipal loop if another transmitter interferes.

E.G.R. IS POSITIVE NON-INTERFERING SUCCESSIVE. This option allows you to specify whether or not the transmitter will monitor the E.G.R. circuit for other transmitters.

If this option is enabled, then all transmissions on the E.G.R. circuit will be monitored for interference. If another transmitter is detected on the E.G.R. circuit, then all pending transmissions will be postponed until the E.G.R. circuit is available.

If a transmission is in progress when another transmitter is detected, then the E.G.R. circuit will be relinquished until the E.G.R. circuit (or municipal loop) is available, at which time all programmed rounds of the code number will be transmitted.

If this option is disabled, then the transmitter will not relinquish the E.G.R. circuit if another transmitter interferes.

LOOP IS MUNICIPAL / SUMMONING. This allows you to specify whether the telegraphic loop should be viewed as a “municipal” loop or a “summoning” loop.

If “municipal” is selected, then the telegraphic loop will remain open between digits and rounds. This enhances PNIS operation.

If “summoning” is selected, then the telegraphic loop will be closed between digits and rounds. This

prevents the last blow (hit) of each digit and each round from being “stretched” through the inter-digit and inter-round time frames. This makes it easier to visually and audibly decode the transmission. This mode is best used when driving devices like air horns, flashing lights, etc., and when the transmitter is the only transmitter on the telegraphic loop.

E.G.R IS MUNICIPAL/SUMMONING. This allows you to specify whether the E.G.R. circuit should be viewed as a “municipal” circuit or a “summoning” circuit.

If “municipal” is selected, then the E.G.R. circuit will remain closed between digits and rounds. This enhances PNIS operation.

If “summoning” is selected, then the telegraphic loop will be open between digits and rounds. This prevents the last blow (hit) of each digit and each round from being “stretched” through the inter-digit and inter-round time frames.

TIMING. This option allows you to enter the transmitter’s basic timing element. Timing may range from 0.125 second (1/8) to 4.0 seconds, in .0625 second (1/16) increments. Entries between 0.125 and 4.0 will be rounded to the nearest 1/16 second. For example 1.787 would be rounded to 1.8125 (1 and 13/16ths).second timing.
Timing is based on Standard Municipal Ratio.

LOOP LIVE TIME. This option allows you to specify the amount of time that the telegraphic loop must be continuously undisturbed before a transmission will begin. This will provide an “inter-transmit” delay after another transmitter has finished transmitting, and following the repair of a broken telegraphic loop.

This is NOT a fixed delay after an input circuit trip. If the telegraphic loop was continuously undisturbed for “live-time” before the input circuit was tripped, then transmission will begin immediately. Example: Assume that “live-time” = 7 seconds, and that another transmitter finished transmitting, and closed the telegraphic loop 2 seconds prior to an input circuit trip. Transmission will begin 5 seconds after the trip (if the telegraphic loop remains continuously undisturbed).

“Live-time” may range from 0 to 255 seconds (4.25 minutes).

LOOP DEAD TIME. This option allows you to specify the amount of time that the telegraphic loop must be continuously open before an E.G.R. transmission will be attempted.

This is NOT a fixed delay after an input circuit trip. If the telegraphic loop was continuously open for “dead-time” before the input circuit was tripped, then E.G.R. transmission will be attempted immediately. Example: Assume that “dead-time” = 15 seconds, and that telegraphic loop opened 4 seconds prior to an input circuit trip. An E.G.R. transmission will be attempted 11 seconds after the trip (if the telegraphic loop remains continuously open).

“Dead-time” may range from 0 to 255 seconds (4.25 minutes).

BULLDOG TIME-OUT. This option allows you to specify the amount of time that transmission attempts can be made before a “bulldog” operation is performed.
Time counting begins when the input circuit is tripped.

Note that the “maximum number of tries” may occur before the bulldog time-out.

“Bulldog-time” may range from 0 to 255 minutes (4.25 hours).

MAXIMUM ATTEMPTS TO TRANSMIT BEFORE BULLDOG. This option allows you to specify the “maximum number of tries” that a transmission will be attempted

before a bulldog operation is performed.

“Maximum number of tries” may range from 0 to 255 minutes (4.25 hours). Note that the “bulldog-time-out” may occur before the “maximum number of tries”.

Default Settings

The on-board EEPROM holds the default operating configuration. It is loaded into the microprocessor’s memory whenever the microprocessor is reset, including power-up. The configuration data is checked for integrity, and if it is found to be corrupted (e.g. a bad EEPROM chip, a damaged PC board, etc.) then the transmitter will use the factory defaults.

Input Defaults

Circuit	Alarm Code	Trouble Code	Alarm Rounds	Trouble Rounds
1	81	91	4	5
2	82	92	4	5
3	83	93	4	5
4	84	94	4	5
5	85	95	4	5
6	86	96	4	5
7	87	97	4	5
8	88	98	4	5
9 (L.E.)	89	99	4	5

	ENABLE / DISABLE	NO/NC	All Ones allowed	Embedded zeros allowed
All	Enabled	NO	No	Yes

	Trouble if Suspended	Trouble on EGR	Alarm Bulldog	Trouble Bulldog
All	Yes	No	Yes	No

Transmitter Defaults

Loop: Positive Non-Interfering Successive, Municipal E.G.R.:
Positive Non-Interfering Successive, Municipal

Timing: 1 / 4 (0.25) Second
 Live Time: 7 Seconds
 Dead Time: 7 Seconds
 Bulldog Time: 30 Seconds
 Maximum Number of Attempts: 3

Kingfisher Company, inc.
81 Old Ferry Road, Lowell MA 01854
Phone: (978) 596-2014 Fax: (978) 596-2017
Email: Sales@kfci.com Website: www.kfci.com